

ECOLOG-NET LA8 & WA8



**from Firmware Version LA8 & WA8 1.07
and elproLOG NET Version 3.33**

Table of contents

1. Product description	4
2. General application and safety information	6
3. Configuring the datalogger for the network	14
4. Settings in elproLOG ANALYZE	16
5. Defining threshold values and alarm parameters	20
6. Menu	22
7. Functions of collective alarm contact	24
8. Pin assignment and connectors	25
9. Alarm diagrams	28
10. Status and error codes	29
11. Transmitters	30
11.1 Temperature with PT100	30
11.2 Humidity	31
11.3 Pressure	32
11.4 Differential Pressure	33
11.5 CO ₂	34
12. General information	35
12.1 Measuring range, operating range and accuracy	35
12.2 Viewing ranges	35
12.3 Accessories	36
12.4 Dimensional drawing	37
12.5 Revision history	37
Index	38



In the interest of our customers, we reserve the right to perform alterations resulting from subsequent technical developments without any particular notice. For this reason, diagrams, descriptions and information concerning the scope of delivery are not binding!

This manual is valid from firmware version 1.07 and elproLOG 3.33

Used symbols & identification codes



Symbols

	IMPORTANT INFORMATION, WARNING
---	---------------------------------------

	Note
---	------

	Cross reference to related chapter or document
---	--

Identification code

Network	Logger	Part No.	Abbreviation & special chapter
LAN	LA8	2720	...A8
LAN-PoE 12VDC	LA8	2720 & 2730-A	...A8 &  2.8 <i>Power over Ethernet</i>
LAN-PoE 24VDC	LA8	2720 & 2730-B	...A8 &  2.8 <i>Power over Ethernet</i>
WLAN	WA8	2722A8

Evaluation software

Identification in this document

elproLOG ANALYZE	elproLOG ANALYZE
elproLOG ANALYZE-QLS	elproLOG ANALYZE

For a detailed description see elproLOG ANALYZE operation manual (SE3003E) and software OnLine help.

1. Product description

8-channel
4-20mA
64,000 data points
UPS



ECOLOG-NET LA8 & WA8 dataloggers are network-compatible (LAN or WLAN) 8-channel dataloggers with a capacity for recording 64,000 data points. 4-20mA signals can be collected. The data are loaded to the PC via local network. Even in the event of a power failure, all the logged data is retained and the internal clock keeps running. If the sensor power supply should be available during a power failure, then the datalogger power supply unit must be fed with 115/230VAC by an UPS (uninterruptable power supply). There are various alarm features provided by the local alarm contacts and the network functions.

1.1 Datalogger

Connections
Key pad

Battery protection

Removal of this slip causes the first "System Reset" entry in the datalogger status!

Wait 10s after the battery protection has been removed till the datalogger is operable



The ECOLOG-NET LA8 & WA8 has a number of connection points at the left side of its casing. The front side has a display and a key pad.

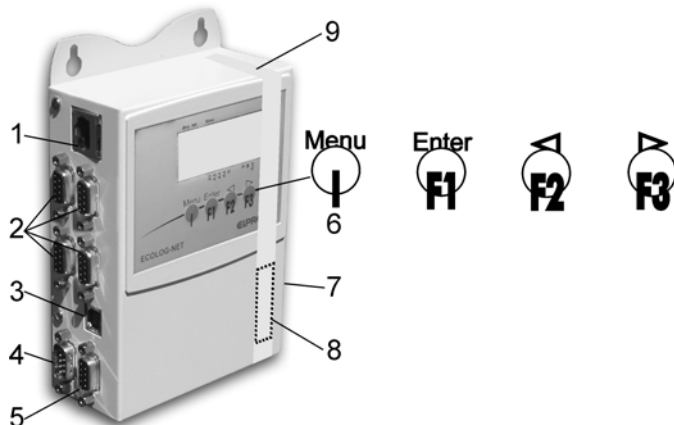
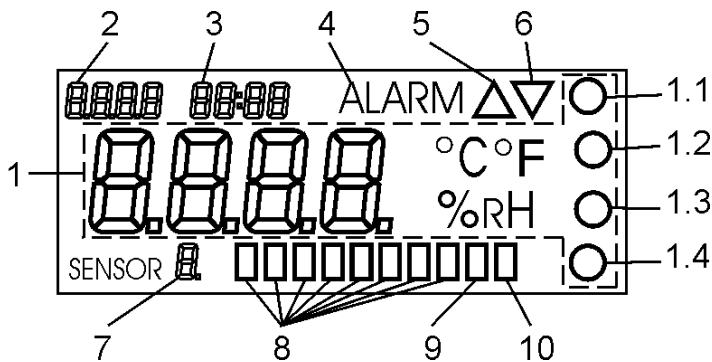

Fig. 1

1. Network connection
2. 8 x 4...20mA input
3. USB connection
4. Power supply, digital inputs & alarm output
5. Alarm output
6. Key pad with 4 buttons
7. Type label with ID number and IP address
8. Battery
9. Battery protection

1.2 Display



Large LCD display for measured values, unit of measurement and states

EN

Fig. 2

1. Measured value with unit of measurement and 4 user-definable units of measurement at 1.1, 1.2, 1.3 and 1.4, (☞ 4.1.4 Axis Assignment)
2. Date or communication via USB or LAN connection
3. Time
4. Alarm
5. Measured value above upper threshold value
6. Measured value below lower threshold value
7. Sensor number
8. Alarm from sensor 1...8
9. Data logging running
10. Battery low (☞ 2.5 Battery back-up / lifetime)

1.3 Technical alterations - CE - WEEE

In the interest of our customers, we reserve the right to perform alterations resulting from subsequent technical developments without any particular notice. For this reason, diagrams, descriptions and information concerning the scope of delivery are not binding!

- This product must be certified with CE.



- The manufacturer guarantees that this product complies with the relevant guidelines:
EN 61000-6-2 : 2001 and EN 61000-6-4 : 2001



- Waste treatment of this product has to comply with WEEE (Waste electrical and electronic equipment, 2002/96/EC)!

2. General application and safety information

2.1 Communication

USB connection

LAN connection



The ECOLOG-NET family of dataloggers are fitted with a 10/100 Base T network connection point. All logger functions and network configurations can be executed via this connection.

Additionally, the dataloggers have a USB connection point. This connection can be used to set dataloggers parameters and to perform data readouts if no network connection is available. However, it can not be used to define network parameters. Data exchange via LAN is not possible when both connection points are occupied.

The datalogger requires an external power supply to operate The LAN interface. After connecting the power supply, it takes approx. 1 minute until the datalogger is addressable via the LAN.

Proceed as follows to achieve a trouble-free USB connection:

1. Connect the power supply to the datalogger and switch on the PC
2. Do not connect the USB cable until both units are ready for operation
3. The Windows driver relevant for the implemented USB connection must be installed. If a suitable driver is not available, use the elproLOG ANALYZE software CD to install one.
4. elproLOG ANALYZE: options - connection options - RS232 & 57600 (Hoseries 4) & appropriate COM-port.

2.2 Influence of temperature

- For the range of application,  12.1 *Measuring range, Operating range and accuracy.*
- It can not be guaranteed that the loggers will function properly at temperatures outside the specified threshold range. Experience has shown that the battery freezes at approx. -50°C, that it is no longer possible to perform measurements and that the timer tracking function can be temporarily interrupted. To make further operation possible, the logger must be reprogrammed when room temperature is reestablished.

- The legibility of the display is impaired when temperatures fall below - 20°C. However, long-term use does not present any problems.
- Lithium battery passivation, due to long-term use at temperatures exceeding 40°C, can result in temporary read problems (self-discharge protection). Perform repeated evaluation to rectify this problem.
- Battery self-discharging increases at temperatures exceeding 45°C and continuous operation at temperatures above 45°C can reduce battery lifetime by approx. 1/3.
- Exposure to temperatures exceeding 55°C can result in permanent discoloration of the display.
- There is danger of a gas explosion when the lithium battery heats up to temperatures exceeding 100°C.

2.3 Exceptional environmental conditions

Pay attention to the following when dataloggers are used under exceptional environmental conditions:

- IR radiation (heat) and superheated steam can damage the surface coating on the casing
- There is a risk that the battery may explode if the logger is used in conjunction with microwaves

Initial startup



 **THE DATALOGGER MUST BE AT ROOM TEMPERATURE PRIOR INITIAL STARTUP!**

2.4 Precautionary measures for handling units containing lithium batteries

- Do not short-circuit and charge batteries: explosion hazard
- Do not throw units which contain batteries into fire: explosion hazard
- Do not subject batteries to mechanical stress and do not dismantle them. The leaking battery fluid is highly corrosive and lithium can generate severe heat when it comes into contact with moisture or it can ignite fire.
- Do not heat up battery-driven units to temperatures exceeding 100°C: explosion hazard
- Avoid violent knocks and blows

Lithium batteries



- Follow the manufacturer specifications for storing batteries
- Return batteries to the supplier for correct waste disposal

2.5 Battery back-up / lifetime

Battery lifetime

Power-save mode 

...A8

Battery lifetime of approx. 3 months for the current datalogger version in the event of a total power failure (back-up).

Battery low

This indicator ( 1.2 *Display*) is activated when the battery capacity limit is reached.

Replace the battery at the next possible opportunity in accordance with the instructions in ( 2.11 *Maintenance*).

2.6 Logger display / Power-save mode

The ECOLOG-NET datalogger has a power-save mode which switches off the display. As a result, measurements are only made during the defined log interval. 4 small circles located in the display indicate that the datalogger is functioning and recording correctly.

The elproLOG ANALYZE software (Extended Setup - Display mode / Powersave) switches the power-save mode on and off. ...A8 datalogger types go automatically into power-save mode when no external power supply is available. If you need to make a check, use the keypad to switch on the display temporarily.

2.7 Threshold values function / Alarm conditions

ECOLOG-NET ...A8 dataloggers have a feature for monitoring threshold values. The threshold values are defined separately for each individual sensor ( 5. *Defining threshold values and alarm parameters*).

The ECOLOG-NET can signal a threshold violation in various ways:

Threshold violation 

1. A threshold violation is shown on the display; signaling is always sensor-specific. Both arrowheads indicate a threshold violation ( 1.2 *Display*). They are visible for

the actual duration of the threshold violation only. This status is not logged.

2. ALARM is displayed when the conditions for an alarm are fulfilled. It is dependent on the selected alarm output (self-sustaining)
3. In the case of an alarm being triggered, the ECOLOG-NET has a collective alarm function. This function is activated simultaneously at the time the text ALARM is displayed.  7. *Functions of collective alarm contact* & 9. *Alarm diagrams*.
4. After the alarm delay time, an alarm is not registered in the memory until the subsequent log interval has elapsed. All threshold violations / alarms are registered in the alarm protocol, even when they are shorter than the defined log interval!

Use the PC software or the keypad to acknowledge alarm messages.

Acknowledging alarm messages 



DURING NORMAL OPERATION, THE THRESHOLD VALUES ARE CHECKED EVERY 4 SECONDS OR AT THE DEFINED LOG INTERVAL IF A SHORTER TIME HAS BEEN SET.

IN POWER-SAVE MODE, THRESHOLD VALUES ARE MONITORED EITHER IN 1 MINUTE CYCLES IF THE LOG INTERVAL IS LONGER THAN 1 MINUTE OR AT THE DEFINED LOG INTERVAL IF SHORTER INTERVALS HAVE BEEN SET. THE FOLLOWING TEXT IS DISPLAYED WHEN THE CONDITIONS FOR AN ALARM ARE FULFILLED IN POWER-SAVE MODE: ALARM AND, IN ADDITION, ALA.

THRESHOLD VALUES ARE NOT MONITORED WHEN THE LOGGER IS IN STOP MODE.

Monitoring thresholds values during normal or power-save mode 

2.7.1 Timing Collective Alarm

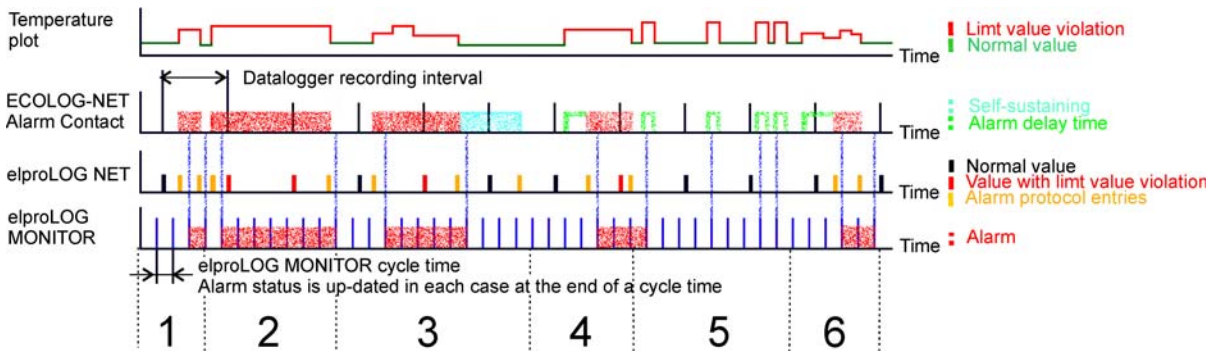

- 1 Alarm is shorter than the datalogger recording interval**

ECOLOG-NET Alarm contact reacts immediately.

ANALYZE No alarm measurement, because the alarm is shorter than the log interval, alarm protocol with 2 entries - alarm on/off.

MONITOR Represents an alarm for 1 cycle time. Alarm status is up-dated at the end of a cycle time.
- 2 Alarm logged**

ECOLOG-NET Alarm contact reacts immediately

ANALYZE 2 alarm measurements, alarm protocol with 2 entries - alarm on/off.

MONITOR Represents an alarm over 7 cycle times.
- 3 Alarm with self-sustaining; logged**

ECOLOG-NET Alarm contact reacts immediately.

ANALYZE 1 alarm measurement, alarm protocol with 2 or 3 entries - alarm on/off/(quit ...P4 only).

MONITOR Represents an alarm till the end of the limit value violation (5 cycle times). The duration of the self-sustaining period is not represented as alarm.
- 4 Alarm with delay time; logged**

ECOLOG-NET Alarm contact reacts after the delay time has elapsed.

ANALYZE 1 alarm measurement, alarm protocol with 2 entries - alarm on/off. „Alarm on“ is logged after delay time has elapsed.

MONITOR Represents an alarm over 3 cycle times. The end of the third cycle falls already into a new, delayed alarm, therefore it wont be recognized as alarm..

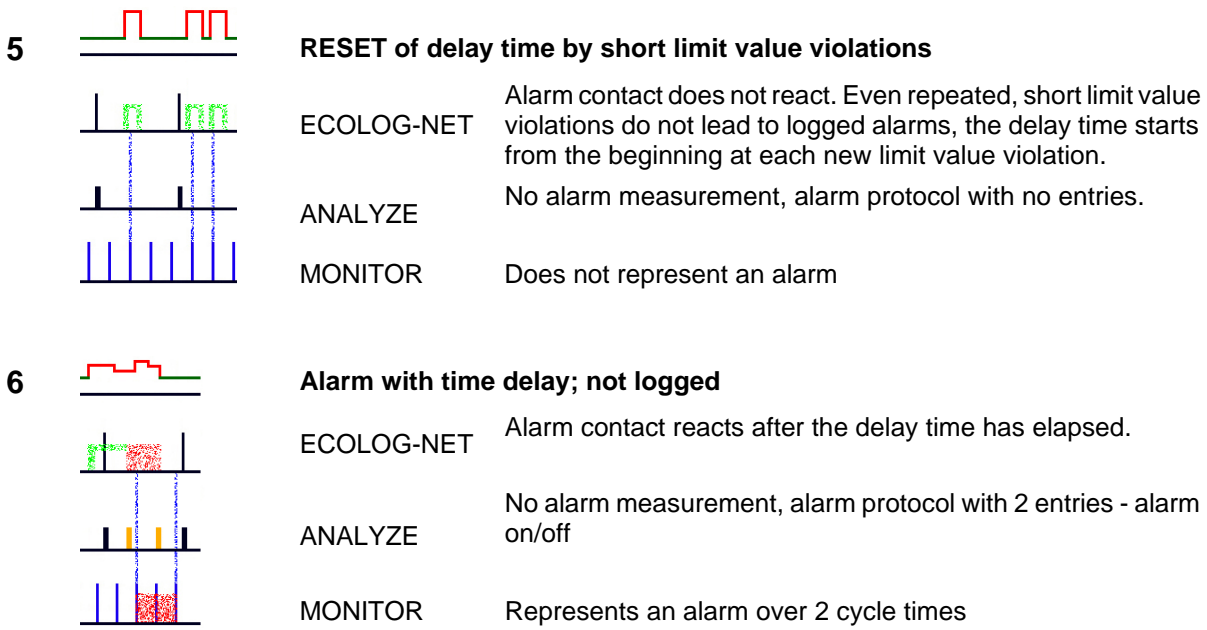

2.8 Power over Ethernet

ECOLOG-NET LA8 dataloggers can be equipped with an additional PoE module. This option means that the datalogger can be operated without any additional external power supply unit. Pay attention to the following for datalogger operation with a switch that supports the PoE option:

- The datalogger supports standard IEEE 802.3 af (phantom supply not supported)
- PoE does not work on a Gigabit-Ethernet LAN
- The following diagram (Fig. 3) shows the pin assignment for the RJ45 connector in accordance with IEEE 802.3 af with spare pairs. The coloring coding complies with T568B:

PoE
Part No. 2370

A green LED on the PoE module (inside of the housing back plane) shows the functioning of the PoE module.



- | | | |
|---|----------------|-----|
| 1 | orange / white | RX+ |
| 2 | orange | RX- |
| 3 | green / white | TX+ |
| 4 | blue | V+ |
| 5 | blue / white | V+ |
| 6 | green | TX- |
| 7 | brown / white | V- |
| 8 | brown | V- |

Fig .3

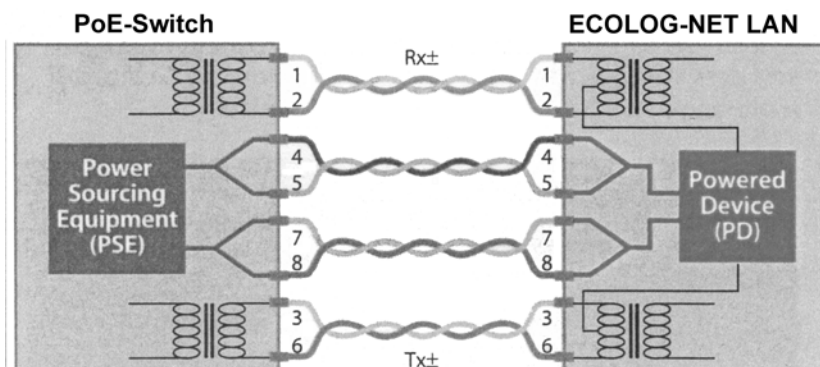

2.9 elproLOG ANALYZE Function: Overlaying



At present, mutual overlaying is not available for dataloggers LA8 / WA8.

2.10 Digital Inputs D1 and D2

**Both inputs are occupied with dual functions!
In each case one function should be used only**

Function	Possible Configuration			
Time stamp	D2 Key	D2 Key		
Defrost on	D1 external		D1 external	
Alarm forwarding		D1 external	D2 external [#]	D1 external; D2 external [#]

D2 Key See function F2, time stamp indicate as D2  6. *Menu*
This function can be used to register incidents (e.g. a watchman's patrol) at the logger.

D1 external Defrost on ( 5. *Defining threshold values and alarm parameters*) or for alarm forwarding.  8.3 *Socket 7; DB9; male*

Alarm forwarding  8.3 *Socket 7; DB9; male*

- Status of D1 and D2 are not documented in the alarm protocol and they do not influence the alarm switches. These inputs are show in the evaluation software elproLOG ANALYZE, measurement table as D1, D2 or MarkPos.

Alarm forwarding 

- Alarm forwarding is used by the elproLOG MONITOR software. The status (Alarm / no Alarm) of both inputs will be checked during the up-date of the elproLOG MONITOR data. A status change between two up-dates wont be detected.

2.11 Maintenance

To ensure proper datalogger functioning, the following steps should be part of a periodic maintenance schedule:

- Calibrate the datalogger
- Perform datalogger readout and save the data; test the alarm function, if implemented
- Replace the battery  12.4 *Dimensional drawing* (Part No. 2820, set of 2, storable for at least 5 years / lithium 3.6V, 1900mAh, AM3/LR6/AA)

Maintenance-schedule 

An energy consumption count is used to monitor datalogger battery life. For this reason, only the specific manufacturer-recommended battery should be used. Do not remove the battery from the logger when it is not in use. The use of other batteries or removal of batteries will produce incorrect status information at the battery indicator.

Battery 

Replacing battery 



RESET THE BATTERY CHANGE TIME AFTER YOU REPLACE THE BATTERY (ELPROLOG ANALYZE SOFTWARE - EXTENDED SETUP - PROGRAMMING BATTERY CHANGE TIME...) OTHERWISE THE ENERGY COUNTER WILL NOT FUNCTION CORRECTLY!

3. Configuring the datalogger for the network

elproLOG ANALYZE
elproLOG MONITOR
DigiDeviceDiscovery 

For datalogger identification within a network environment, an unambiguous network address is assigned to each datalogger. This address is made up of 3 different types of information: IP address, subnet mask and default gateway. We recommend the use of a fix IP address for programs elproLOG ANALYZE & elproLOG MONITOR.

To avoid network conflicts, the network administrator should allocate the network address! The 3 types of address information must be entered manually at every datalogger with the help of software: Digi Device Discovery.

3.1 Desktop installation

The relevant network address is assigned to the datalogger during this workstep. This work should be performed at the place of use prior to final installation, e.g. in an office.

3.1.1 Communication test

Check the network configuration and perform a functional communication test

3.1.2 Documentation

Document the performed configuration. Keep a written record of the network parameters on a status printout from the datalogger and...



..make a note of the IP address on the datalogger type label. This is the simplest way to identify the datalogger during installation!

3.1.3 Additional settings for ECOLOG-NET WLAN

SSID, channel, encryption



ECOLOG-NET service manual

For any further details concerning a WLAN installation, see your local network documentation please.

Service manual:
[www.elpro.com/Download/Data sheets/ECOLOG-NET networkable datalogger/ECOLOG-NET service manual IT6001A.](http://www.elpro.com/Download/Data%20sheets/ECOLOG-NET%20networkable%20datalogger/ECOLOG-NET%20service%20manual%20IT6001A) 

3.2 Installing the datalogger

3.2.1 Installation

Mount the datalogger at the place of use in accordance with the network plan and connect the sensor probes.

3.2.2 Communication test

Check communication - PING

3.2.3 elproLOG CONFIG

This software is used for organizing the dataloggers within the network environment. The dataloggers can be grouped together within the network to form groups or logic units. Both elproLOG ANALYZE and elproLOG MONITOR work with this information. For more information about using this software,  SC3001E.

elproLOG CONFIG 

3.2.4 elproLOG ANALYZE

Set the datalogger parameters,  4. *Settings in elproLOG ANALYZE* and 5. *Defining threshold values and alarm parameters*.

The ECOLOG-NET LA8 & WA8 have 8 measuring channels. Any 4 of these 8 channels can be viewed with the elproLOG ANALYZE software at one time  4.1.1 *Procedure for first setup*.

elproLOG ANA-
LYZE 

3.2.5 elproLOG MONITOR

This program is used for online viewing of measured values. For a detailed description of the functions and applications,  SM3001E.

elproLOG MONI-
TOR 

3.2.6 Installation verification

Check the installation and make sure that the sensor positions, alarm parameters and network address are correct. To help, use auxiliary devices (e.g. calibration connector) to simulate defined measured values.

4. Settings in elproLOG ANALYZE

4.1 Datalogger setup

Datalogger setup 

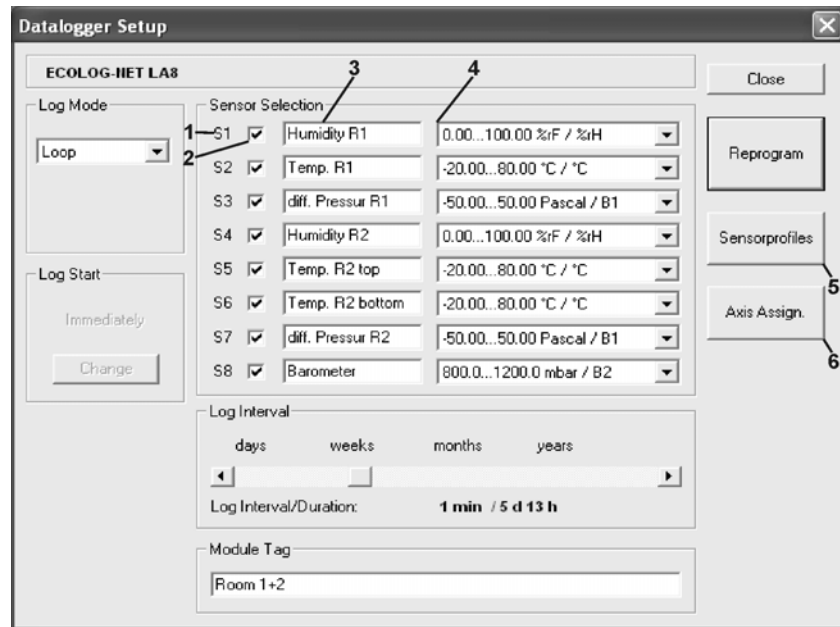



Window "Datalogger Setup" is used to define the implemented measuring parameters.

- Mode
- Log Start
- Log Interval
- Module Tag
- Close, Reprogram

4.1.1 Procedure for first setup

For easy setup of the datalogger we recommend the following procedure:

1. Define sensor profiles  4.1.3 Sensor Profiles
2. Datalogger setup
3. Proceed with assignment according  4.1.4 Axis Assignment

4.1.2 Sensors

1. Sensor number S1 ... S8
2. Check box to select measuring channel
3. User-defined name for measuring channel
4. Measurement range selection. One of the 8 predefined measurement ranges can be assigned to the measuring channel.
5. Opens the window used to set the parameters for the 8 possible measurement ranges 4.1.3 Sensor Profiles
6. Opens the window used to map the channels to the 4 axes of the displayable elproLOG graphics 4.1.4 Axis Assignment

4.1.3 Sensor Profiles

Sensor Profiles

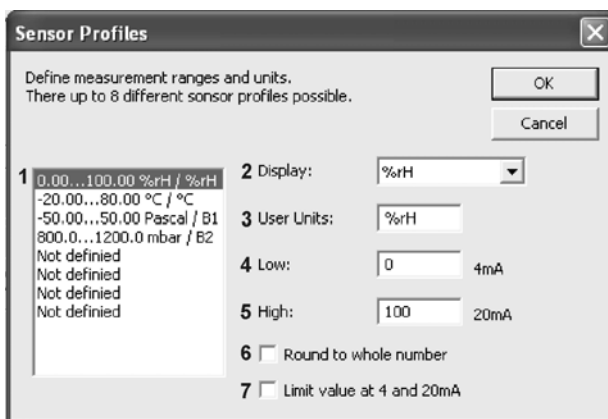

1. By selecting a channel, it is possible to define range and unit see point 2 - 6
2. Menu to select the display unit.
Units of measurements °C, °F and %rH are shown on the datalogger display. For all other units select a display bullet (Bullet 1 - 4). The bullets are numbered in descending order from (1) to (4) 1.2 Display
3. The graphic function of elproLOG ANALYZE is able to represent up to 4 independent y-axes. The text for the defined unit should not include a " ; ". The semicolon is specified as default separating character for communication with elproLOG MONITOR.
4. Measurement scaling in accordance with sensor settings for the **lower** limit of the measurement range.
5. Measurement scaling in accordance with sensor set-

- tings for the **upper** limit of the measurement range.
- 6.** Scaled measurements are in whole numbers.
- 7.** Limit function for measurement values outside the allowed 4-20mA definition.
 Values above 20.4mA result in O.F.
 Values below 3.6mA result in U.F.
 N.C. ist not shown  **10.** Status and error codes

4.1.4 Axis Assignment

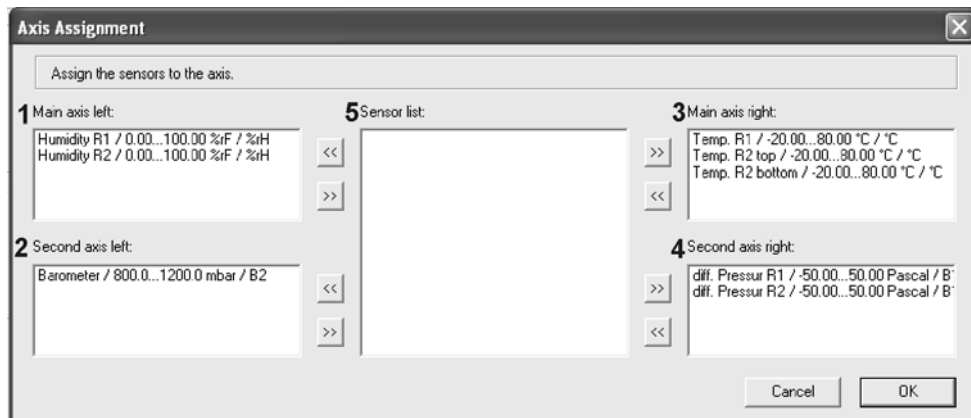

Axes



1. 2. 3. 4.

Sensor assignment to one of the 4 possible y-axes. There are 2 main axes; 1 and 3 and 2 secondary axes; 2 and 4 (2 axes) available. The difference between all 4 axes may be range and value. The main axes are the dominant axes for scaling of the line chart.

5.





Sensor list of all possible sensors which are not assigned.



The same axis may sensors be assigned with the same range and same unit only.

4.2 Extended setup



Name	Function
Set date of calibration check	This function protocols the current date of calibration in the datalogger status.
Define alarm parameters...	<p> 5. <i>Defining threshold values and alarm parameters</i></p> This window is also used to switch the integrated alarm buzzer on/off
Reset alarm	Used to acknowledge and reset an alarm
Set date and time...	Used to adjust the integrated datalogger clock
Configure logger display...	<p> 2.6 <i>Logger display / Power-save mode</i></p>
Configure communication settings...	Settings for terminal mode communication <p> D-HC-6001Ax</p>
Set temperature unit...	Used to select the unit of measurement used for temperature. You can choose between °C and °F.
Set new password...	<ul style="list-style-type: none"> - Used to set a password. - Reset a password. Enter the password into line: "Old Password" only
Programming of battery change time...	Used to restart the datalogger after battery replacement ( 2. <i>General application and safety information</i>).

5. Defining threshold values and alarm parameters

Threshold values and alarm parameters are defined in window "Setup of Alarm Parameters". Threshold monitoring is only performed at sensors which are selected for a measurement function. The following conditions trigger an alarm:

Conditions



- The measured value must lie outside the defined tolerance range; i.e. the measured value is higher than the maximum allowable threshold value or lower than the minimum allowable threshold value.
- The threshold violation must exceed the defined alarm delay times.
- The threshold violation remains active until the measured value reaches the defined tolerance range again.

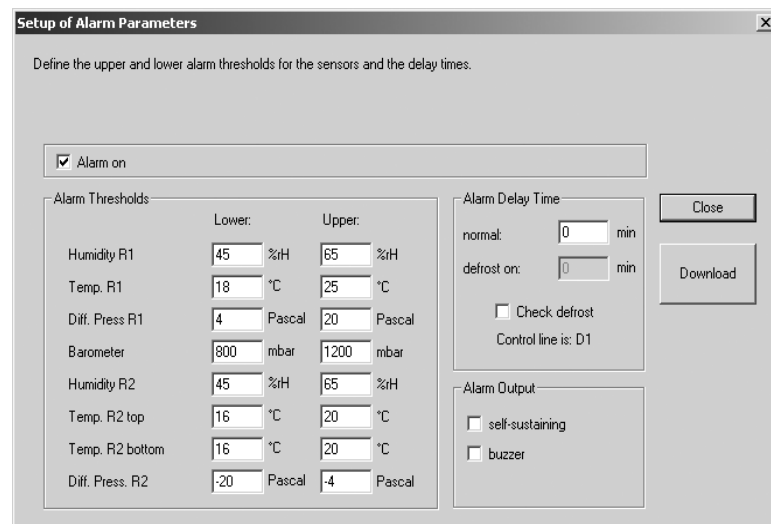
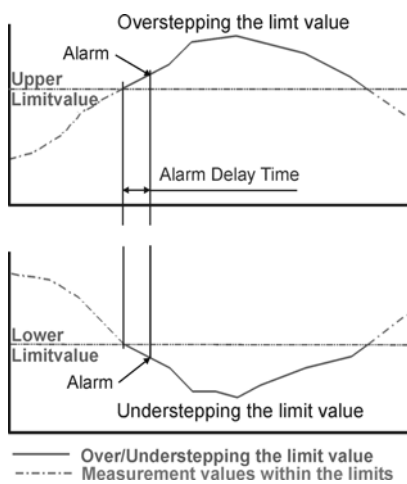

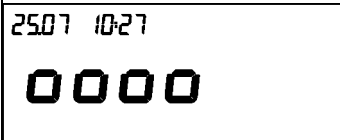

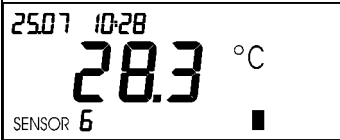

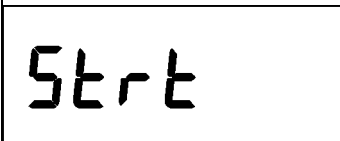

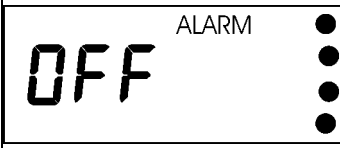









Fig. 4







5.1 Window: Setup of Alarm Parameters

Name	Function
Alarm on	Activate this checkbox to switch on the alarm threshold function, 2.7 <i>Threshold values function / Alarm conditions.</i>
Alarm Thresholds	Data enter fields for the lower and upper thresholds.

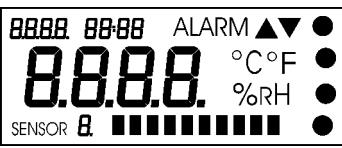
<p>Alarm Delay Time</p>	<ul style="list-style-type: none"> - normal An alarm is not triggered until the threshold violation has lasted longer than the specified time. - defrost on If the "Check defrost" function is active and defrost contact D1 is closed, then an alarm is not triggered until the threshold violation has lasted longer than the time specified at this enter field.
<p>Alarm Output</p>	<ul style="list-style-type: none"> - no selection made The following text is displayed for the duration of the threshold violation: ALARM. The alarm contact is closed for the duration of the threshold violation. - self-sustaining This mode is used for all applications where the alarm contact controls an external device such as a flash or a telephone dialing unit. The following text is displayed until a manual reset is executed: ALARM. The alarm contact remains closed until a manual reset is executed. - buzzer Switches the buzzer on/off
<p>Close / Download</p>	<p>These buttons are used to program the datalogger and to close the "Setup of Alarm Parameters" window.</p>

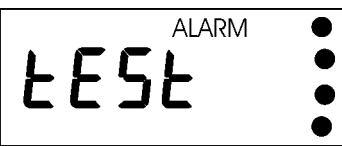
6. Menu

1	<p>Power-save mode</p> 	<p>4  only appear when the datalogger is in power-save mode and is logging data. Press the menu key to activate the display for a few seconds.</p> <hr/> <p> Temporary jump to menu item 2</p>
2	<p>Measuring mode</p> 	<p> Jump to menu point 3 or 4 or 5; situation-dependent</p>
3	<p>Start</p> 	<p>Only appears when the datalogger is in start/stop mode and is waiting for the start time. StoP, ALA, dISP,  10. <i>Status and error codes</i></p> <hr/> <p> Jump to menu item 5</p>
4	<p>Acknowledgment</p> 	<p>Only appears when the "self-sustaining" function is selected and an alarm display is active  5.1 <i>Window: Setup of Alarm Parameters</i></p> <hr/> <p> Jump to menu item 5</p> <p> Reset alarm display and alarm contacts; time stamp in the alarm protocol; exit menu, jump to menu item 8</p> <p> Exit menu, jump to menu item 8</p>
5	<p>Functions</p> 	<p> Jump to menu item 6</p> <p> Time stamp indicated as D2; exit menu, menu item 8  2.10 <i>Digital Inputs D1 and D2</i></p> <p> Exit menu, jump to menu item 8</p>

6	<p>LCD display test</p> <div style="border: 1px solid black; padding: 5px; display: inline-block; margin-bottom: 10px;">  </div> <p>  Jump to menu item 7 </p> <p>  Exit menu, jump to menu item 8 </p>
7	<p>Alarm output test</p> <div style="border: 1px solid black; padding: 5px; display: inline-block; margin-bottom: 10px;">  </div> <p>  Jump back to menu item 4 or 5 </p> <p>  OFF - ON - OFF </p> <p>  Exit menu, jump to menu item 8 </p>
8	<p>Exit menu</p> <p style="text-align: center;">Automatic jump back to menu item 1 or 2 or 3</p> <div style="border: 1px solid black; padding: 10px; margin-top: 10px;"> <p style="text-align: center;">- - - -</p> </div>



ERROR 5; MODULE DOES NOT RESPOND DURING DATA READ-OUT

- THE DATALOGGER IS NOT IN MEASURING MODE
- PRESS F1/F3 TO EXIT THE MENU

7. Functions of collective alarm contact

Alarm signaling:

- Relay contact A
- Alarm 1
- Alarm 2
- Buzzer



Datalogger type ECOLOG-NET ...A8 has 4 possibilities for alarm signaling:

- Relay contact S
This is a potential-free switch-over contact. The contact switches when an alarm is triggered or when the external power supply fails.
- Semiconductor contact Alarm 1
This contact reacts with an alarm only
This is a semiconductor switch - break contact to data-logger GND
- Semiconductor contact Alarm 2
This contact reacts with an alarm only
This is a semiconductor switch - make contact to data-logger GND
- Integrated buzzer
Acoustic alarm signal

 5.1 Window: Setup of Alarm Parameters

8. Pin assignment and connectors

Wire the DB9 connectors for the ECOLOG-NET...A8 as shown below:

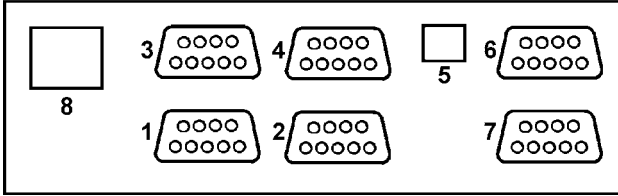

Fig. 5

1. Signal 1 and 2
2. Signal 3 and 4
3. Signal 5 and 6
4. Signal 7 and 8
5. USB connection for local evaluation and programming
6. Alarm
7. Power supply
8. RJ45 for network connection

8.1 Sockets 1 - 4; DB9; female

Pin	Signal	Function
1	Gnd	Ground
2	Gnd	Ground
3	SA	Signal input (int. shunt to ground; 50-100Ω)
4	V sens	Sensor power supply (logger operating voltage)
5	Gnd	Ground
6	Gnd	Ground
7	Gnd	Ground
8	SB	Signal input (int. shunt to ground; 50-100Ω)
9	V sens	Sensor power supply (logger operating voltage)

Connector with
metallised housing
Part No. 2754-MT

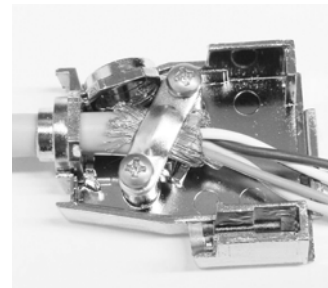

FOR CABLE LENGTH > 30M, SHIELDED CABLES HAVE TO BE USED. SHIELD MUST BE IN GOOD CONTACT WITH CONNECTOR HOUSING.

Connecting a 2/3-wire transmitters



Connecting a 2-wire transmitter

Sensor A: + at 4; signal at 3; (possibly shielding at 2)
 Sensor B: + at 9; signal at 8; (possibly shielding at 7)

Connecting a 3-wire transmitter

Sensor A: + at 4; signal at 3; - at 5; (possibly shielding at 2)
 Sensor B: + at 9; signal at 8; - at 6; (possibly shielding at 7)

8.2 Socket 6; DB9; female

alarm
 white housing
 Part No. 2754-WS

Pin	Signal	Function
1	Sb	Alarm switch (relay contact)
2	Gnd	Ground
3	Gnd	Ground
4	Alarm 1	Alarm output
5	V out	Alarm power supply (logger operating voltage)
6	Sc	Alarm switch (relay contact)
7	Sa	Alarm switch (relay contact)
8	Gnd	Ground
9	Gnd	Ground

Alarm switch
Alarm output 1

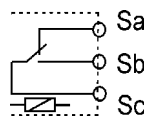

Alarm switch (relay contact)

Alarm switch (relay) shown in currentless state.

This relay is activated as soon as power is applied.

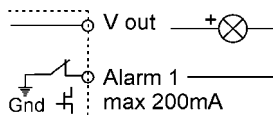

Alarm output 1 (make contact)

8.3 Socket 7; DB9; male

power supply
digital inputs & alarm
red housing
Part No. 2754-RT

Pin	Signal	Function
1	Alarm 2	Alarm output
2	D1 ext.	Contact input
3	D2 ext.	Contact input
4	Gnd	Ground
5	V in	Power supply (logger operating voltage)
6	Gnd	Ground
7	Gnd	Ground
8	Gnd	Ground
9	Gnd	Ground

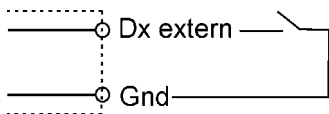

Contact input 1 & 2

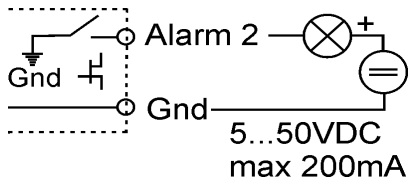

Alarm output 2
(make contact)

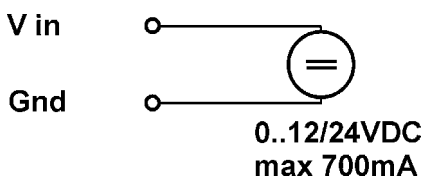

Power supply

Contact input 1 & 2
Alarm output 2
Power supply



9. Alarm diagrams

9.1 Socket 6; white housing

Alarm with local power supply

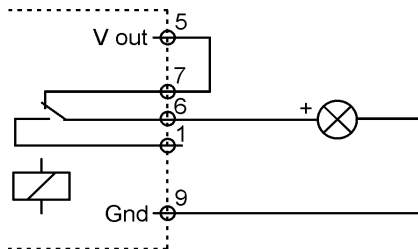

- Requires power supply for signaling
- Alarm triggered by threshold violation
- Switching load max. 42VAC or VDC; 500mA

Alarm with power supply monitoring and cable break monitoring

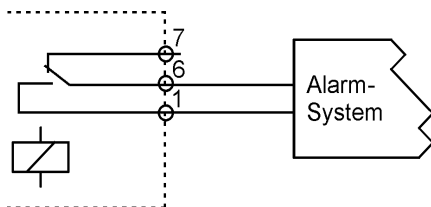

- Alarm triggered by threshold violation or failure of external power supply or cable break
- Switching load max. 42VAC or VDC; 500mA

Alarm with power supply monitoring

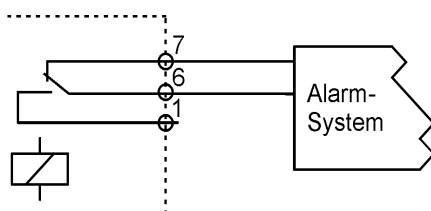

- Alarm triggered by threshold violation or failure of external power supply
- Switching load max. 42VAC or VDC; 500mA

The relay is activated as soon as power is applied

Alarm *without* power supply monitoring but with cable break monitoring

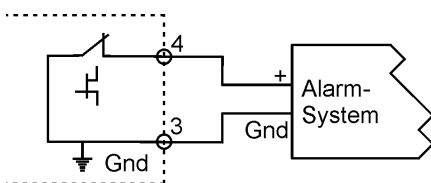

- Alarm triggered by threshold violation
- Datalogger does not require external power supply
- Switching load max. 24VDC or VDC; 200mA

9.2 Socket Socket 7; red housing

Alarm with external power supply

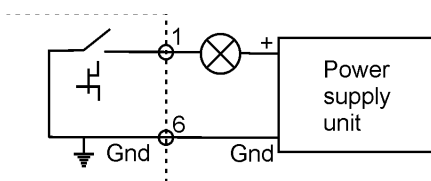

- Alarm triggered by threshold violation
- Switching load max. 24VDC; 200mA

10. Status and error codes

10.1 Datalogger display & elproLOG ANALYZE

Display ANALYZE

ALA	--	Additional alarm text in power-save mode
CON	--	Datalogger communicating with software
USB	--	Communication via USB connection
LAN	--	Communication via LAN connection
dISP	Measured value	Measured value is outside the range which can be shown on the display (-999 ... 9999). However, the measured values are being logged correctly.
Strt	--	Datalogger is waiting for the log start time programmed at menu item: Datalogger Setup
StOP	--	Datalogger is in Start/Stop mode and the memory is full. No further measured values can be logged. Reprogram the logger to restart data logging. Datalogger ...A8 is in this state when it is delivered.
C.Fd	C.F.	Faulty datalogger
N.C.	N.C.	No sensor connected
C.FO	C.F.O	Measured value > 22.0 mA
O.F.	>=max	20.4 mA < measured value <= 22 mA
U.F.	<=min	0.0 mA <= measured value < 3.6 mA
C.FU	C.F.U	Measured value < 0.0 mA

10.2 Status of datalogger in elproLOG ANALYZE

This error message appears in the datalogger status report in line: Module time. The cause of this error message can, for example, be a battery change when the battery change time was not programmed ( 2.11 *Maintenance*).

This error message appears in the datalogger status report in line: "Last reprogrammed". It is the result of the datalogger reset counter.

*RAM IMG-BMP
destroyed*



*System resets since last
reprogramming
All entries in the alarm
protocol will be era-
sed*



11. Transmitters

11.1 Temperature with PT100

Part No. 3350-A

Measuring range according to operating range of sensor

PT100 ML temperature probe with 4-20mA transmitter

Measurement range	PT100 probe-dependent	Catalogue
Probe class	DIN A	
Accuracy	<+/- 0.3°C or <+/- 0.1% of range	
Power supply	8...35VDC	
Connector, Cable, PSU, ...	12.3 Accessories	

Setting parameters

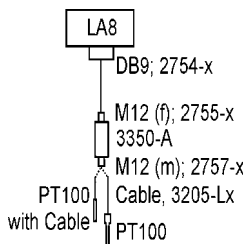
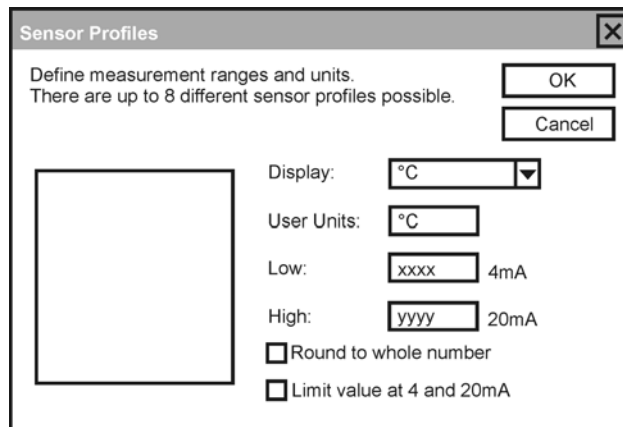

Connection list DB9 and connector M12, 2755-x SA - Temperature 1 & SB - Temperature 2

DB9	Signal LA8	Cable - length < 30m - with connector	Cable - length > 30m - needed 2755-x
3, SA	Temp. 1	blue	yellow
4, Vsens	Supply 1	brown	brown
7, Gnd	Ground 1	white	white
8, SB	Temp. 2	blue	yellow
9, Vsens	Supply 2	brown	brown
2, Gnd	Ground 2	white	white

Wiring of: 2755-x connector: female for cable length > 30m



ATTENTION ! needs DB9: 2754-MT see chapter 8.1

Wiring of: 2757-x connector: male



Connection list connector M12, 2757-x PT100 - Transmitter 4-20mA

Cable length max. 12m

11.2 Humidity

Temperature and relative humidity transmitter EE21

Measurement range	-40...60°C, 0...100%rH
Accuracy at 23°C	+/- 0.3K, +/- 1.5%rH
Power supply	20...35VDC
Connector, Cable, PSU, ...	12.3 Accessories

Setting parameters: Humidity

Setting parameters for temperature

11.1 *Temperature with PT100*

Connection list DB9 and connector M12, 2755-x SA - Temperature & SB - Humidity

DB9	Signal LA8	Cable - length < 30m - with connector	Cable - length > 30m - needed 2755-x
		Wire Color	Wire Color
1, Gnd	Ground	white	white
3, SA	Temperature	black	green
4, Vsens	Supply	brown	brown
8, SB	Humidity	blue	yellow

**Wiring of: 2755-x
connector: female
for cable length > 30m**

brown white
green yellow

**ATTENTION !
needs DB9:
2754-MT
see chapter 8.1**



11.3 Pressure

For example Part No.
3280-A

For further information,
see the original data
sheet



Pressure transmitter

Transmitter	 Catalogue
Measurement range	Pressure transmitter depending
Accuracy at 23°C	<+/- 0.5% of range
Power supply	15...32VDC
Connector, Cable, PSU, ...	 12.3 Accessories

Setting parameters

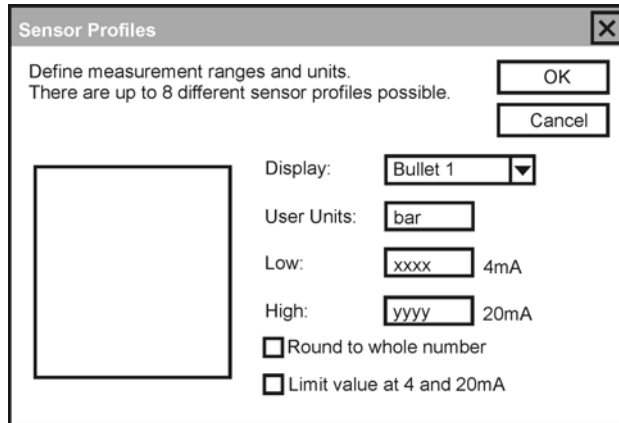

Connection list DB9 and connector M12, 2755-x SA - Pressure 1 & SB - Pressure 2

		Cable - length < 30m - with connector	Cable - length > 30m - needed 2755-x
DB9	Signal LA8	Wire Color	Wire Color
3, SA	Pressure 1	blue	yellow
4, Vsens	Supply 1	brown	brown
7, Gnd	Ground 1	white	white
8, SB	Pressure 2	blue	yellow
9, Vsens	Supply 2	brown	brown
2, Gnd	Ground 2	white	white

Wiring of: 2755-x
connector: female
for cable length > 30m



ATTENTION !
needs DB9:
2754-MT
see chapter 8.1



11.4 Differential Pressure

Differential pressure transmitter

Measurement range	-50...+50Pascal other values on request
Medium	Only air and no aggressive gases
Accuracy at 20°C	<+/- 3Pascal
Operating temperature	0...70°C
Protection class	IP54
Power supply	24VDC
Connector, Cable, PSU, ...	12.3 Accessories

Setting parameters

For example
Part. No. 3260-L
For further information,
see the original data
sheet

EN

Connection list DB9 and sensor terminals SA - dP 1 & SB - dP 2

DB9	Signal LA8	Cable		Terminal
		- length < 30m - with connector	- length > 30m - needed 2755-x	
3, SA	dP 1	blue	yellow	‰
4, Vsens	Supply 1	brown	brown	+
7, Gnd	Ground 1	white	white	0
8, SB	dP 2	blue	yellow	‰
9, Vsens	Supply 2	brown	brown	+
2, Gnd	Ground 2	white	white	0

11.5 CO₂

For example

Part No. 3271-F (wall mounting) or 3271-G (duct mounting)

For further information, see the original data sheet 

CO₂ transmitter

Measurement range	Transmitter depending
Accuracy at 20°C	<+/- [1% of range + 1.5% of value]
Long term stability	<+/- 5% of range / 5 years
Response time	< 60s
Warm-up time	< 5min
Range of application	0...100%rH (non-condensing), -20...+70°C
Power supply	24VDC, 2.5W

Setting parameters

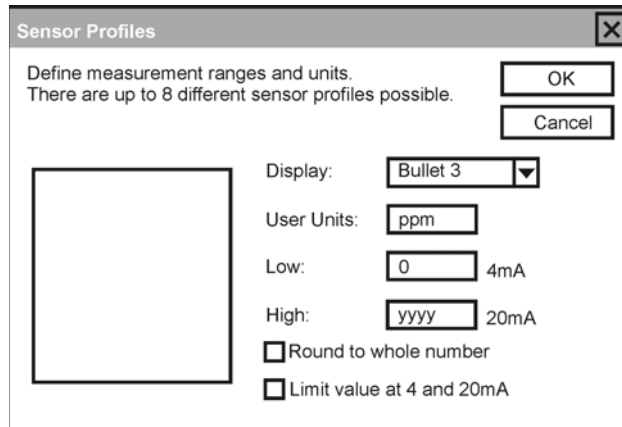

Connection list DB9 and sensor terminals SA - CO₂ 1 & SB - CO₂ 2

DB9	Signal LA8	Cable		Terminal
		- length < 30m - with connector	- length > 30m - needed 2755-x	
3, SA	CO ₂ 1	blue	yellow	mA
4, Vsens	Supply 1	brown	brown	+
7, Gnd	Ground 1	white	white	0
8, SB	CO ₂ 2	blue	yellow	mA
9, Vsens	Supply 2	brown	brown	+
2, Gnd	Ground 2	white	white	0

12. General information

For more product information, see the CD-ROM.

CD-ROM



EN

12.1 Measuring range, Operating range and accuracy

	Range	Resolution	Accuracy
Measuring (over defined temperature range)	3.6mA ...20.4mA	0.003mA	± 0.04mA
Operating range	LA8: -40°C ...55°C WA8: -20°C ...55°C		
Interval	3s ...3h		
Working resistance	50 ...100Ohm		
Protective clase	IP30		
Power supply	U _B 10 ...30VDC LA8: 12VDC; 140mA 24VDC; 70mA WA8: 12VDC; 200mA 24VDC; 100mA		



FURTHER DEVICES WITHIN THE CURRENT LOOP HAVE TO BE POTENTIAL FREE. THE DATLOGGER IS MEASURING AGAINST GRAOUND (SINGLE ENDED)!

12.2 Viewing ranges

Measurement range in user unit	0..2	3..21	22..210	211..2100	> 2100
Resolution per digit (saved value in datalogger)	≤ 0.003	≤ 0.003	≤ 0.03	≤ 0.3	> 0.3
Resolution in ANALYZE	0.001	0.001	0.01	0.1	1.0
Measurement resolution (Representation in "whole numbers" and/or "value delimitation")	The scaled measuring range (3.6mA... 20.4mA) has a resolution of 6242 steps +/- 1 on the last, indicated digit				

12.3 Accessories

Please pay attention to the transmitter's energy requirements. If necessary, use a supply unit with a higher power output.



Part No.	Description
2740-A	Current calibrator
2750-V12	Power supply unit with connector DB9 12V 0.7A [#]
2750-V24	Power supply unit with connector DB9 24V 0.35A [#]
2751-V24	Power supply unit with connector DB9 24V 1.6A [#]
2754-MT	Connector DB9, soldered probes, metallised housing
2754-GR	Connector DB9, male, sensor signal, green
2754-WS	Connector DB9, male, alarm, white
2754-RT	Connector DB9, female, power supply, red
2758-SET	With 2m patch, crossover and USB cables
2730-A	PoE module 12V (factory-installed) PoE module 24V (under developed)
3205-M005	Extension cable for PT100 sensor 0.5m used for cable bushing e.g. refrigerator
3205-Lxx	Connection cable PT100 (up to 12m) with M12 connector
3206-Lxx	Connection cable 4 wires with M12 connector for cable length <30m
2790	Connection cable 4 wires without M12 connec- tor for cable length >30m
2755-Q	Connector M12 (f) with insulation displation contact (IDC)
2755-S	Connector M12 (f) with terminals
2757-Q	Connector M12 (m) with insulation displation contact (IDC)
2757-S	Connector M12 (m) with terminals
2311-xx	diverse flash lights
2820	replacement battery, 2 pieces, 5 year storage time
	Transmitters, probes and connection cables in accordance with ELPRO price list

12.4 Dimensional drawing

EN

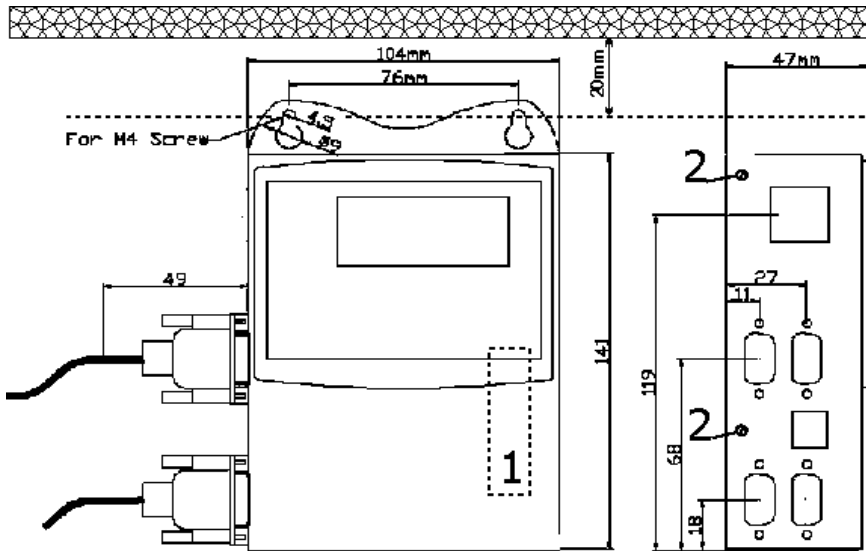

1. Battery; for a battery exchange, the rear wall has to be removed.
2. Screws for the attachment of the rear wall

12.5 Revision history

Author	Date	Version	Description
A. Gubler	27.07.2005	--	First edition
A. Gubler	26.01.2006	a	Chapter 2.7 new and battery protection
A. Gubler	06.05.2006	b	Chapter 4 revised for elproLOG 3.33 and FW 1.07 Chapter 8.1 and plug arrangement new
A. Gubler	26.11.2009	c	Reference to elproLOG ANALYZE operation manual (SE3003E) and OnLine help

Index

Numerics

2/3-Leiter-Transmitter / 26
4-20mA Signal / 4
64'000 Messwerte / 4
8- Kanal / 4

A

Accessories / 36
Accuracy / 35
Acknowledging alarm messages / 9
Additional settings / 14
Alarm conditions / 8
Alarm Delay Time / 21
Alarm diagrams / 28
Alarm forwarding / 12
Alarm output 1 / 26
Alarm output 2 / 27
Alarm output test / 23
Alarm parameters / 20
Alarm protocol / 29
Alarm signaling / 24
Alarm switch / 26
Axis Assignemet / 18

B

Battery / 13
Battery lifetime / 8
Battery low / 8
Battery protection / 4

C

Collective alarm function / 9
Communication test / 14, 15
Configuring the datalogger for the network / 14
Connections / 25
Contact input / 27

D

Datalogger setup / 16
Defining threshold value / 20
Desktop installation / 14
Digital Inputs D1 and D2 / 12
Display / 5

E

ECOLOG-NET LA8 & WA8 / 4
elpro DEVICE DISCOVERY / 14
elproLOG ANALYZE 14, 15
elproLOG CONFIG / 15
elproLOG MONITOR / 14, 15
elproLOG NET Version / 1
Error codes / 29
Exceptional environmental conditions / 7
Extended setup / 19

F

Firmware Version / 1

I

Influence of temperature / 6
Initial startup / 7
Installation / 15
Installation documentation / 14
Installation verification / 15
Installing the datalogger / 15

K

Key pad / 4

L

LAN / 6
Limit value violation / 11

M

Maintenance schedule / 13
Measuring range / 35
Monitoring thresholds values / 9

O

Operating range / 35
Overlaying / 12

P

Pin assignment / 25
Power over Ethernet, PoE / 11
Power supply / 27
Power-save mode / 8
Precautionary measures / 7
Protective clase / 35

R

RAM IMG-BMP destroyed / 29

Replacing battery / 13

S

Sensors / 17

Setting parameters - CO2 / 34

Setting parameters - Differential pressure / 33

Setting parameters - Humidity / 31

Setting parameters - Pressure / 32

Setting parameters - PT100 / 30

Socket 6 / 26, 28

Socket 7 27

Sockets 1 - 4 / 25

Status of datalogger / 29

System resets / 29

T

Technical alterations / 5

Threshold values function / 8

Timing / 10

U

UPS (uninterruptable power supply) 4

USB connection / 6

V

Viewing ranges / 35

W

Working resistance / 35

Head Office:

ELPRO-BUCHS AG

Langäulistrasse 62

CH-9471 Buchs

Switzerland

email: swiss@elpro.com



ELPRO MESSTECHNIK GmbH

Baumwasenstrasse 20/1

DE-73614 Schorndorf

Deutschland

email: brd@elpro.com



ELPRO Services Inc.

P.O. Box 727

210 Mill Creek Road

Marietta, Ohio 45750

U.S.A

email: usa@elpro.com

ELPRO UK Ltd.

Unuit 1, Allen's Yard

Nyton Road, Aldingbourne

Chichester West Sussex PO20

3UA

United Kingdom

email: uk@elpro.com

www.elpro.com